



CJ Rush Classic Revolving Door



Installation & Maintenance Manual

Table of Contents

Installation	3
General Contractor Notes	3
Layout.....	3
Step No. 1.....	3
Step No. 2.....	4
Step No. 3.....	5
Step No. 4.....	6
Step No. 5.....	7
Step No. 6.....	7
Step No. 7.....	7
Step No. 8.....	9
Step No. 9.....	9
Step No. 10.....	11
SERVICE	12
Replacement of Ceiling Lights.....	12
Replacement of Weather Sweeps.....	13
Collapsing of Door Wing to Gain Access to Control and Grease Fitting	13
To Service Bearing.....	14
Adjustment of Overhead Mounted Manual Speed Control	15
MAINTENANCE	17
Cleaning Instructions.....	17
Care and Maintenance of Stainless Steel in Architectural Applications.....	18
Care and Cleaning of Anodized Aluminum	21
PRODUCT DEVELOPMENT	23

Installation

General Contractor Notes

Requirements for installation of revolving door, the general contractor provides:

- 1) All electrical wiring and connections to the ceiling light junction box if ceiling lights are required. (Roughing-in wiring must be in prior to the time of installing).
- 2) Location for revolving door anchorage must be free from electrical conduits and wiring to a depth of 2".
- 3) Floor must be true and level at the interior screen of the revolving door
- 4) Finished floor must be completed before installation of revolving door.

Layout

Step No. 1

- 1) Before beginning layout - ensure finished floor is level & flat. See your installation drawing for confirmation of all dimensions.
- 2) Lay out the center line of the revolver in accordance with the location specified on the installation drawing supplied.
- 3) After determining the center point of the revolver, scribe a circle to mark the INSIDE RADIUS. Refer to installation drawings for dimensions.
- 4) Mark the location of the corner posts in accordance with the installation drawings.

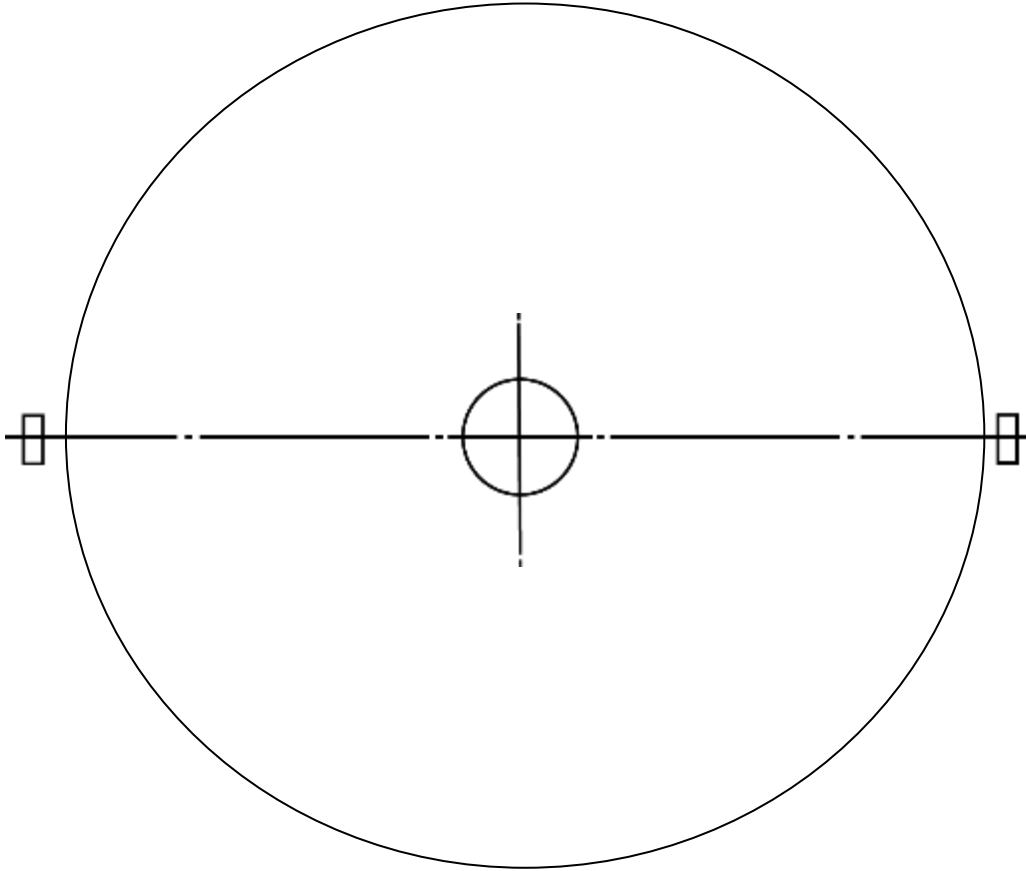

Step No. 2

Mark revolving door opening and face of door as shown on shop drawings. Note: Check diagonals to ensure square accuracy.

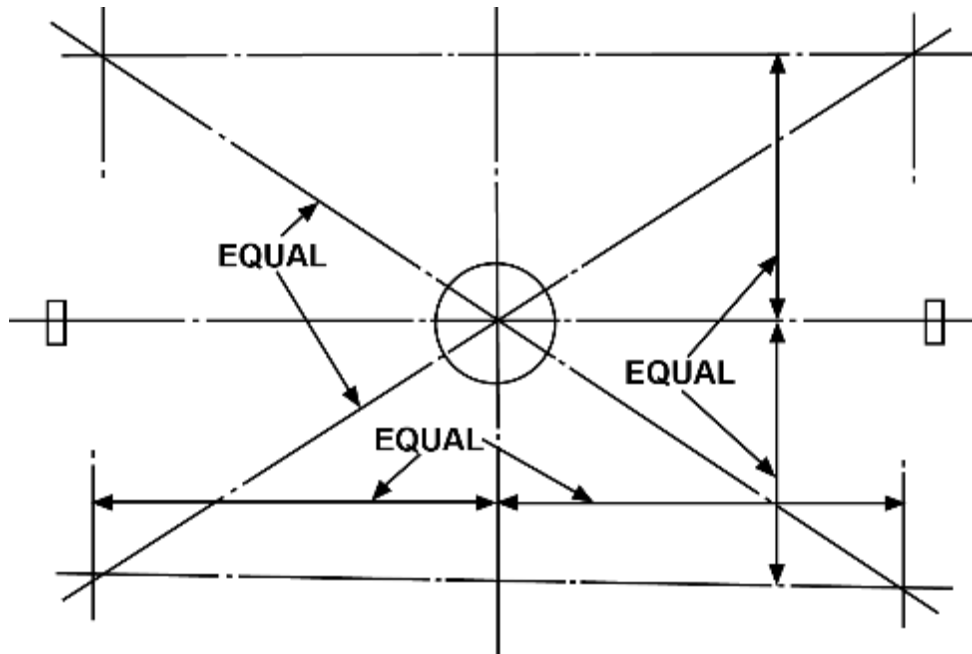

Step No. 3

- a) Move side screens in exact position and mark anchor holes.
- b) Remove screens, drill holes, insert shields and expand shields. Note: Use a flat bar with a hole and a shorter bolt. This will keep the shield from turning when anchoring the screen.

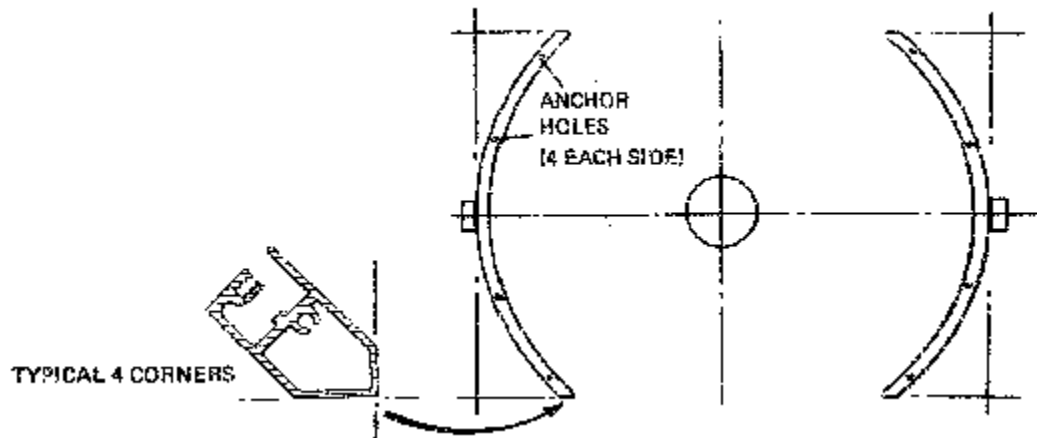



Step No. 4

Assemble roof to side screens with one socket head cap screw on each corner post and two on each center post. Use some caulking on the end of the Allen Key to hold bolt.

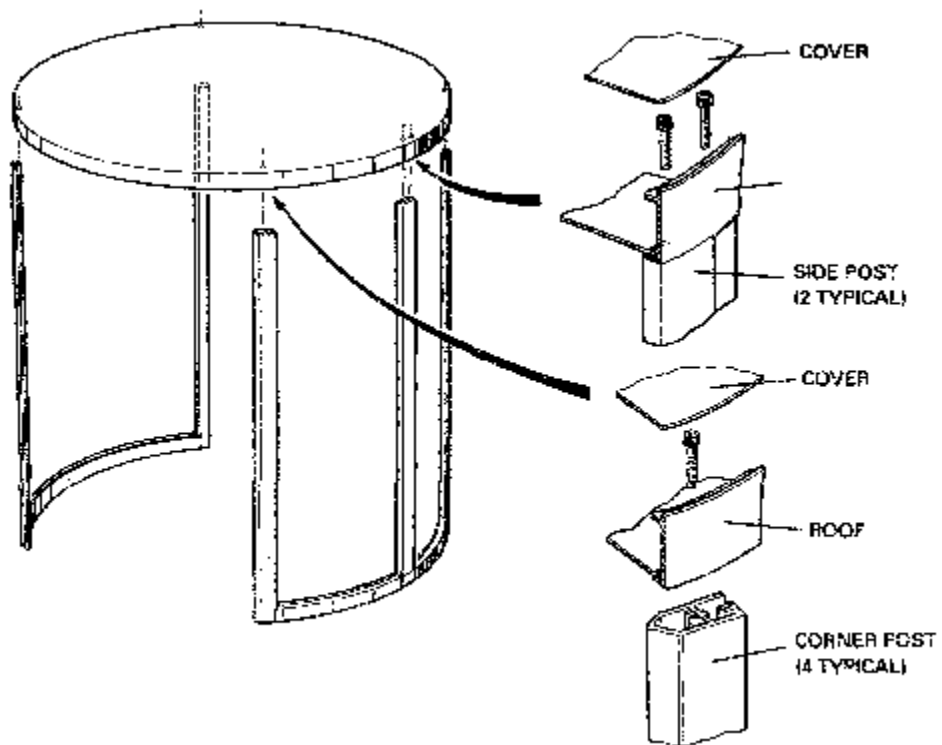

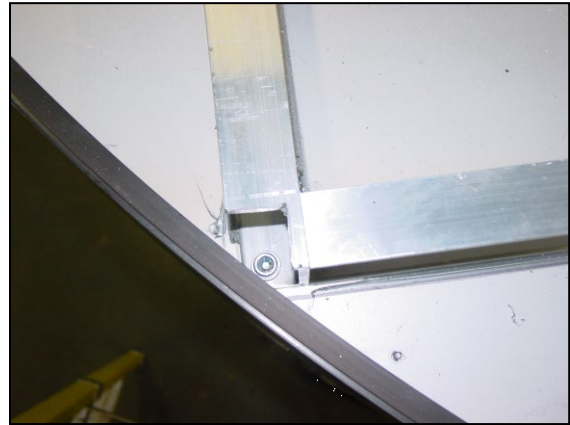

Step No. 5

- a) Move assembly into correct position and anchor to floor, seal holes in roof after installation.
- b) Level base as shown on drawing. To double check level diagonal, shim as necessary and tighten anchoring bolt. Plum door vertical and fasten when possible.

Step No. 6

Position bottom casing at center of door.

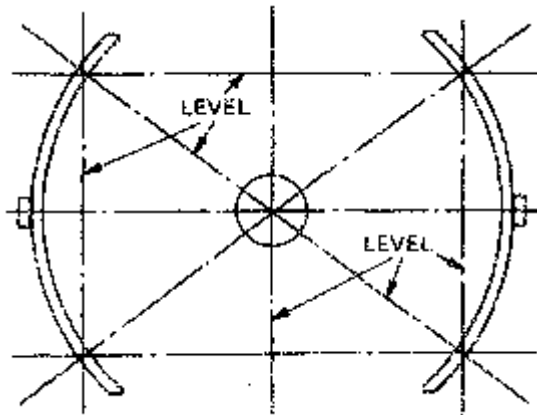

Step No. 7

- a) From the center of the top bearing, plum down to the center of the speed control or motor. For the top bearing use a small piece of shaft with a hole through the middle, just big enough to let the plumb line through or use laser plumb.

- b) Line up the plumb bob with the center mark on the lower collapsing mechanism in the floor casing. Watch for any draft, it may be necessary to erect a piece of plywood or any kind of a screen to let the plumb hang straight. (Not necessary if using laser plumb line.)
- c) Mark holes and drill and anchor casing to floor.



- d) Shim casing if required for level.
- e) After fastening, the floor casing should be checked again as before. If everything checks out, install lower collapsing unit into bottom casing.



Step No. 8

C J Rush Series 500 Revolving Door

Installation & Maintenance Manual

Install curved glass.

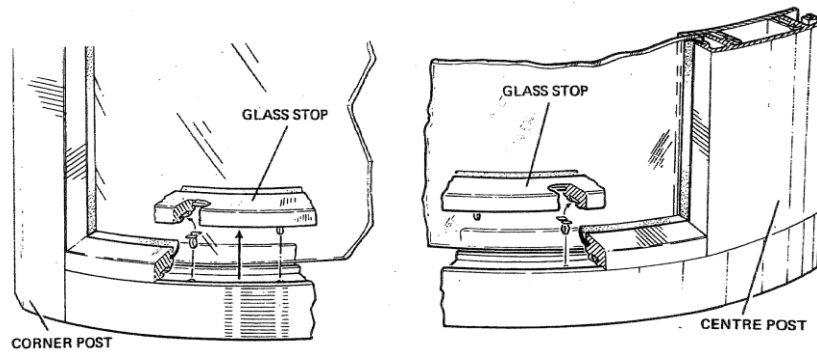

Step No. 9

Install upper collapsing mechanism on top of upper shaft, then insert into ceiling bearing.



Align top of shaft with hole in the upper speed control. Push shaft up and drop lower shaft into hole in lower collapsing mechanism, Ensure that key ways are aligned and Keys in place.

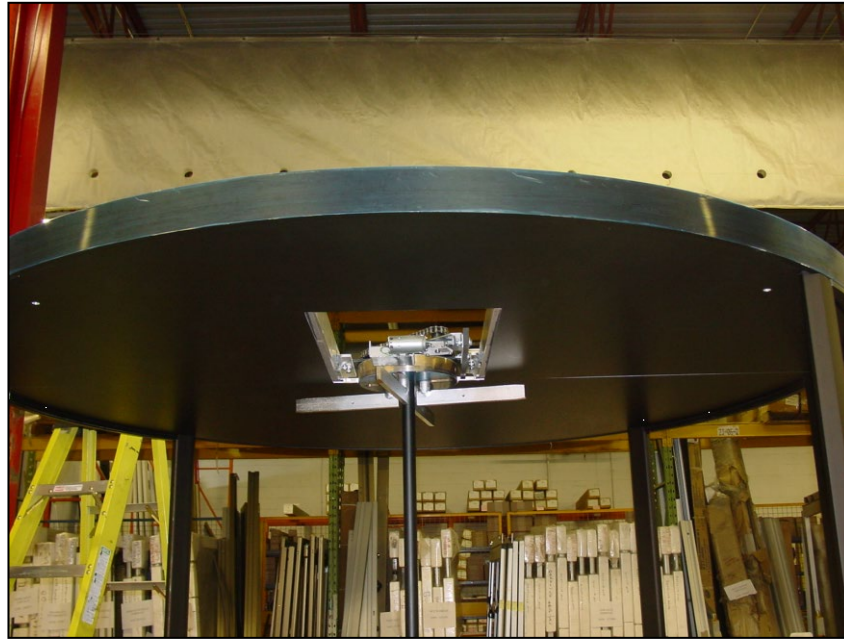

If this becomes difficult to get into position it may be necessary to loosen or remove the bolts holding the upper speed control to allow more room. When the shaft and upper collapsing is in position reinsert or tighten bolts into brackets in ceiling securing shaft and the upper speed control in position.

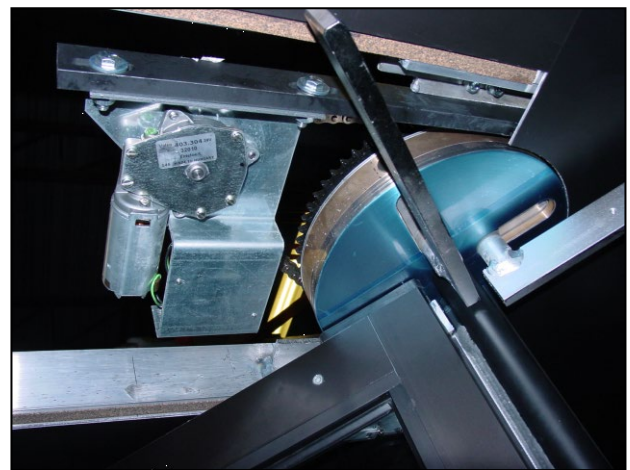
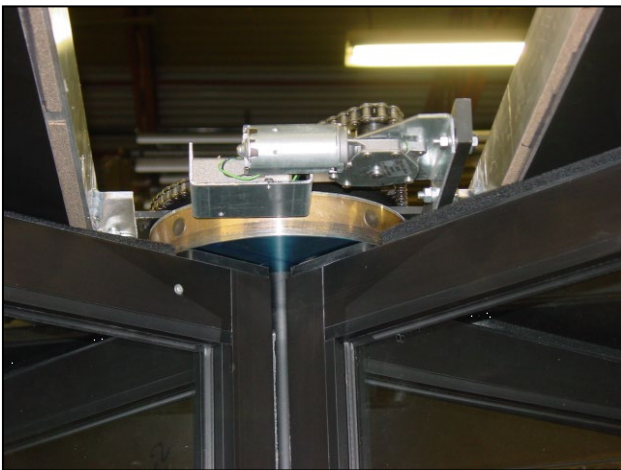

Step No. 10

Install door wings with screws as shown.



SERVICE

Replacement of Ceiling Lights

Assembly as shown below

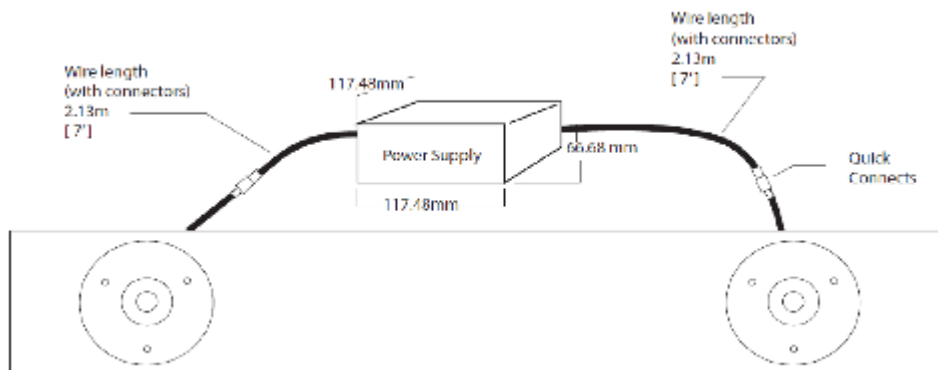
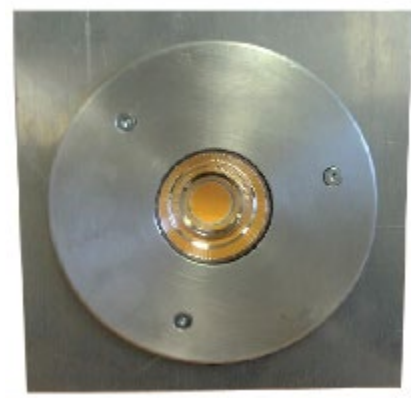

- 1) Turn off lock out main power supply
- 2) Remove three screws from lens cover and remove lens and lens holder.
- 3) Remove screws holding LED lamp
- 4) Unclip from power feed lines.
- 5) Clip new LED lamp onto power feed.
- 6) Screw new lamp into position.
- 7) Replace lens, cover and screws.
- 8) Restore main power back to the unit and test that lamp is operational.

Replacement of Weather Sweeps

- 1) Remove door wings.
- 2) Remove old sweeps (slide out).
- 3) Install new sweeps and join corners.
- 4) Re-install door wing.

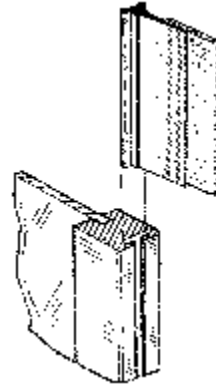

Collapsing of Door Wing to Gain Access to Control and Grease Fitting

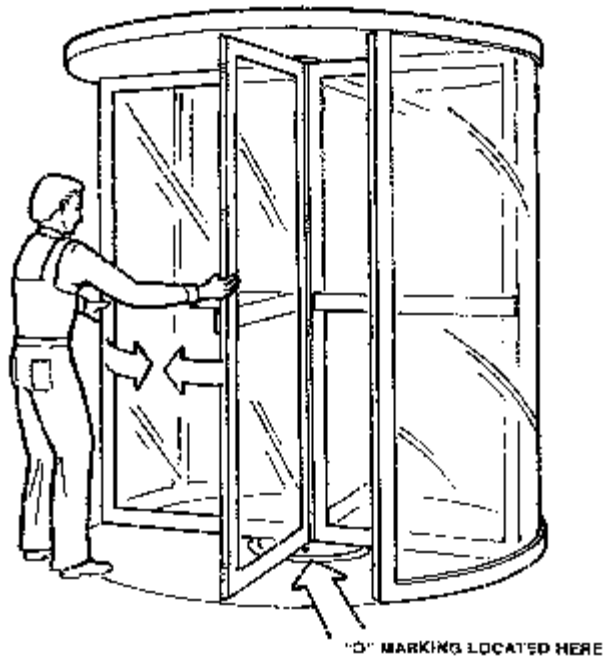

Locate '0'
Adjacent door covers
Access holes

Hold the door wings as shown - pull the side marked '0' with a sharp quick motion to disengage snap-in type mechanism located in the upper and lower hardware. To reset push doors sharply in opposite direction.

To Service Bearing

- 1) Collapse door wing to expose access hole and slowly rotate door wings to locate grease fitting.
- 2) Apply good quality waterproof wheel bearing grease.

Note: This maintenance operation should be performed a minimum of once a year.

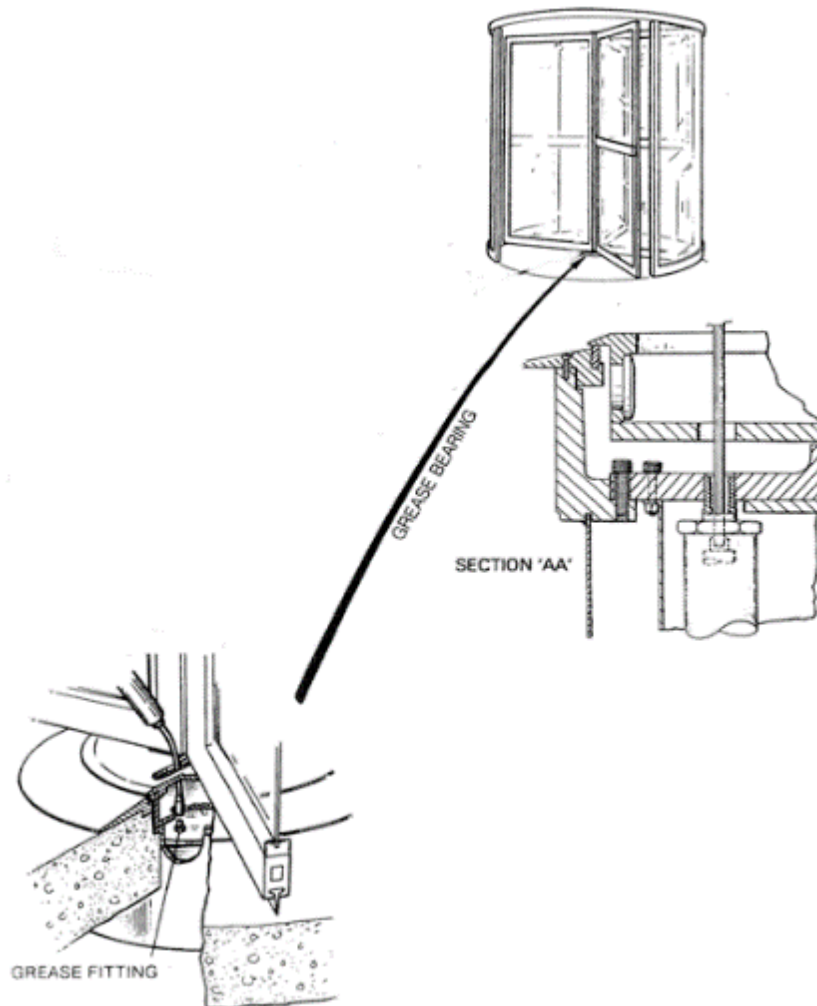

Adjustment of Overhead Mounted Manual Speed Control

Units are factory set. However, if control needs adjusting due to job conditions, proceed as follows:

- 1) Remove access panel in ceiling
- 2) Locate control box as shown in Photo #1
- 3) Remove cover as shown in Photo #2
- 4) Locate blue adjustment block and turn screw to adjust speed as shown in Photos #3 & #4.
 - a) Turn clockwise to increase speed
 - b) Turn counterclockwise to decrease speed
- 5) Replace cover and access panel.

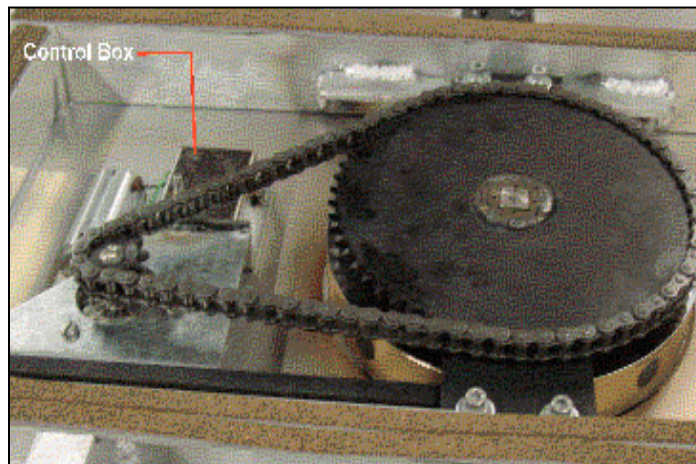

Photo #1

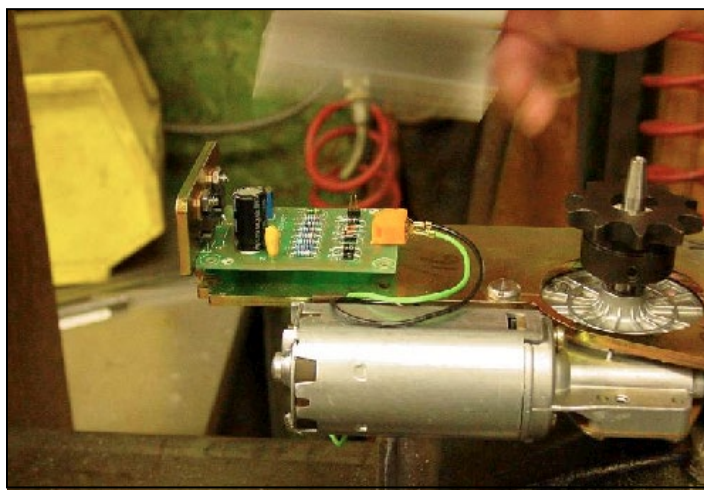

Photo #2

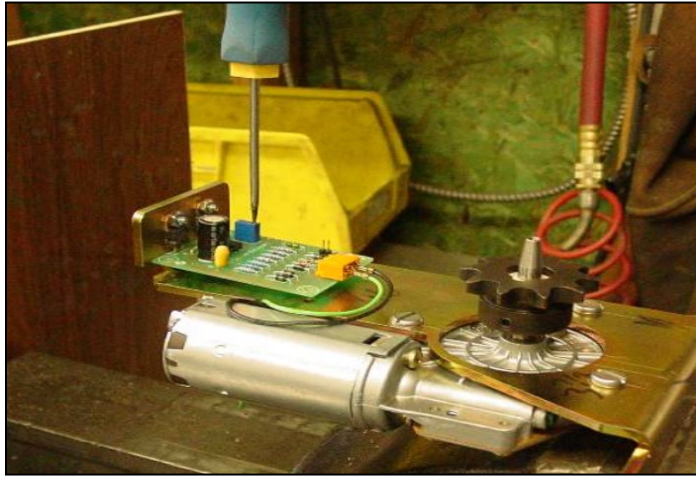

Photo #3

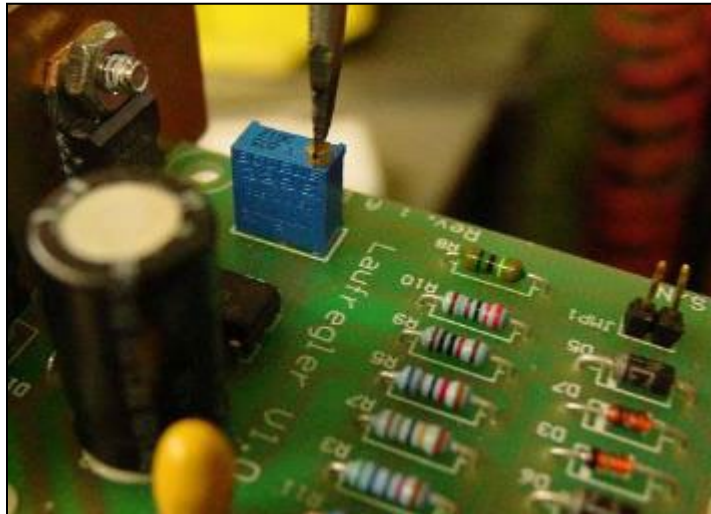

Photo #4

MAINTENANCE

Cleaning Instructions

- 1) Clean glass with water or regular glass cleaner. Avoid having cleaner come in contact with cement on all glass door wings as this will cause cement to deteriorate.
- 2) Clean aluminum or stainless steel with mild detergent and rinse well with clean water. Dry with soft cloth. Do not use abrasive cleaners.
- 3) During winter months, avoid using excessive ice-melting chemicals; also wash frequently to remove accumulated salt and slush.
- 4) Cleaning painted and stainless-steel finishes

THE CARE AND CLEANING OF PAINTED MATERIAL: Today's factory applied heat cured painted finishes are durable and very colorfast. The Kynar® and Hylar® PVDF resin-based products that meet the AAMA 2605 specification with trade names such as Duranar® by PPG, Fluropon® by Valspar, Shernar® by Sherwin Williams or Trinar® by Akzo-Nobel are warranted to retain their color and gloss level for many years. However, to assure that they retain their original beauty, even these highly durable finishes should be cleaned occasionally. When selecting a cleaning solution use mild soap solutions that are safe for use with your bare hands such as those products that one would use to wash a car. Avoid the use of strong acid or alkali cleaners as they may damage the finish.

Solvents no stronger than mineral spirits or denatured alcohol may be used to remove grease, sealants or other materials. Never mix cleaners or cleaners and solvents as the resultant mixture can cause harmful or even dangerous results. Do not use abrasive cleaners or materials such as steel wool or abrasive brushes, which can also harm the surface.

Once heavy soil, grease or sealant is removed the mild soap solution should be applied with a soft cloth, sponge or soft brush. Rinse the surface thoroughly with clean water and dry with a soft cloth.

In coastal areas where the finish is exposed to salt spray or in areas containing heavy industrial pollutants the cleaning should take place on a regular basis. For example cleaning the painted finish can be scheduled as a part of the regular maintenance program for glass cleaning.

Care and Maintenance of Stainless Steel in Architectural Applications

Architectural applications for stainless generally specify the use of T304 stainless steels. This grade is an austenitic stainless steel.

It is specified in the following common architectural finishes:

- Imperial Finish** - a matte gray textured finish similar to a shot blasted pattern
- Ezeform Finish** - a rolled pattern finish available in both a bright and dull lustre
- #8 Mirror** - a highly polished reflective finish (mirror type finish)
- #4 Satin** - a general purpose finish produced by abrasive belt polishing of cold rolled sheet
- XL Blend S** - a finish similar to #4 but finer in texture, handling marks, scratches, and minor surface damage are readily masked by localized re-grinding on this finish

All stainless architectural materials are supplied in the passivated or corrosion resistant condition. They do require periodic cleaning just as other materials do when in service. Exterior components for example are subjected to road salt spray at ground level and deposits from polluted urban air at higher levels, Finger marks, deposits from tobacco smoke, and other stains can detract from the original, attractive appearance of interior stainless applications.

One of the outstanding features of stainless steels is the ease with which its fine appearance can be maintained. There are some important considerations that should be understood by those charged with the responsibility to care and maintain these architectural products.

General Precautions:

- 1) Wash all stainless areas regularly with warm water and mild soap or detergent using a clean cloth or soft brushes.
- 2) The frequency of regular maintenance cleaning will depend on the degree of contamination and the aesthetic needs of the individual user, in the case of exterior panels, once a year is the minimum recommended practice. Interior areas may need frequent attention at ground level due to finger marks etc. with higher levels receiving yearly or twice yearly attention.
- 3) Do not allow dirt to accumulate. Remove any stubborn grime using recommended cleansers and methods, do not use ordinary steel wool or other metal scrapers to remove stubborn dirt as these will contaminate the stainless and mar the architectural finishes. Do not use harsh, abrasive untested cleaners in stubborn areas.

- 4) Do not allow the cleaning agent to come in contact with cement on all glass door wings as this will cause cement to deteriorate
- 5) As tapes, resins and finishes react differently to certain cleaning agents, it is recommended to test the cleaning agent on a low visibility area to check for surface discoloration before proceeding. It is advisable to work on reasonably small sections at a time, e.g. 4' x 4'.
- 6) Always clean in the direction of original polish or grit lines.
- 7) Always rinse after cleaning and blow dry or wipe dry.

Routine Cleaning:

- 1) Rinse with water to remove as much soil as possible.
- 2) For normal stains, air born dirt, etc., apply a soap or liquid detergent product or 5% ammonia solution in water (preferably warm) to the panels.
- 3) Rinse well with water.
- 4) Remove excess water ensuring that all strokes are in the same direction (following the polish lines) preferably top to bottom and overlapping and let dry. The use of a "squeegee" is helpful in facilitating this drying process.

SPV Adhesive Tape Residue:

Surface protective materials when peeled off the stainless can leave minor amounts of tape residue on the surface which can facilitate the adherence of airborne dirt particles. Proper removal is desirable to maintain good overall appearance.

- 1) Rinse with water to remove superficial dirt.
- 2) Apply a stainless cleaner and polisher or organic solvents (e.g. methyl hydrate or rubbing alcohol) or paint or lacquer thinners with a rag, sponge or fiber brush with a soft nylon or natural bristle using long, light strokes.
- 3) Rinse well with water.
- 4) If necessary, repeat the above steps until all tape residue is removed.
- 5) Remove excess water ensuring that all strokes are in the same direction (following the polish lines) preferably top to bottom and overlapping and let dry. The use of a "squeegee" is helpful in facilitating this drying process.

Oil or Grease Marks:

- 1) Rinse with water to remove as much deposits as possible.
- 2) Where grime contains significant amounts of oil or grease, apply an organic solvent such as acetone, ether, alcohol, toluol, xylol, benzol, benzine, naptha or a 5 to 15% caustic soda solution (hot or cold) with a sponge or rag.
- 3) Rinse well with water.
- 4) Remove excess water ensuring that all strokes are in the same direction (following the polish lines) preferably top to bottom and overlapping and let dry. The use of a “squeegee” is helpful in facilitating this drying process.

Rust Discoloration:

- 1) Rinse with water to remove superficial dirt.
- 2) To remove rust spots from carbon steel contamination or high temperature discoloration marks, apply a nitric acid solution (one part of nitric acid to nine parts of warm water) and let it stand for 30 to 60 minutes before rinsing. Wear rubber gloves and always follow manufacturer’s dilution instructions. It is recommended that the minimum concentration and resident time to accomplish the job be employed.
- 3) Rinse well with water.
- 4) Remove excess water ensuring that all strokes are in the same direction (following the polish lines) preferably top to bottom and overlapping and let dry. The use of a “squeegee” is helpful in facilitating this drying process.

Finger Marks:

- 1) Rinse with water to remove superficial dirt.
- 2) To remove finger marks and smears, and suppress their appearance in heavy traffic areas, apply a soap or liquid detergent product or organic solvent (e.g. acetone, alcohol, methylated spirits) to the panels.
- 3) Rinse well with water. Remove excess water ensuring that all strokes are in the same direction (following the polish lines) preferably top to bottom and overlapping and let dry. The use of a “squeegee” is helpful in facilitating this drying process.

Special Precautions on Polished Finishes:

- 1) **#8 Mirror** - because of the highly reflective nature of this finish, it is necessary to take extra precautions to minimize scratching and marring of this finish. In some cases it may be necessary to remove the contaminant and re-buff the surface to restore to the original lustre.
- 2) **#4 Satin and XL Blend S** - because these finishes have a grit line pattern always rub following the polish lines using sufficient pressure to remove adherent dirt particles and stains. For stubborn cases, abrasive cleaners may be used. Household cleaning powders such as Ajax, Comet, Dutch Cleanser*** may be applied using a damp cloth following the polishing lines.

Note: Experimentation in a low visibility area to check for surface discoloration is advised, in some cases, it may be necessary to remove the contaminant and re-polish the surface to restore to the original appearance. This re-polishing is easily done with Scotchbrite*** pads or grinders in the case of XL Blend S.

*** Proprietary cleansers listed are not an endorsement of a specific product and is only intended to serve as examples of the type of cleaning agents that are commercially available. All products should be tested prior to usage and always follow the manufacturer's instructions and directions of use.

Care and Cleaning of Anodized Aluminum

Cleaning Procedures

Cleaning procedures for aluminum should be initiated as soon as practical after completion of installation to remove construction soils and accumulated environmental soils and discolorations.

Cleaning work should start at the top of the building and proceed to the ground level in a continuous drop. Using a forceful water spray, an area the width of the stage or scaffolding should be rinsed as cleaning proceeds from the top down.

Because surface soils may be light or heavy, several progressively stronger cleaning procedures may be employed depending of the severity and tenacity of the soil. Only trial and simplest procedure to remove the soil is the one that should be used.

For light soils, the simplest procedure is to flush the surface with water using moderate pressure. If soil is still present after air-drying the surface, scrubbing with a brush or sponge and concurrent spraying with water should be tried. If soils still adhere, than a mild detergent cleaner should be used with brushing or sponging. Washing should be done with uniform pressure, first horizontally then vertically. Following the washing the surfaces must be thoroughly rinsed by spraying with clean water.

If it is necessary to remove oil, wax, polish, or other similar materials, MEK or an equivalent solvent is

recommended for clean up. Extreme care must be exercised when using solvents of this type are used since they may damage organic sealants, gaskets and finishes. These solvents should never be used on anodic finishes protected by clear organic coatings unless the organic coating has deteriorated and should be removed.

Removing heavy surface soils may require the use of an abrasive cleaning pad. In this procedure the pad is thoroughly soaked with clean water or a mild detergent cleaner and the metal surface is hand scrubbed with uniform pressure. Scrubbing action should be in the direction of the metal grain. Scrubbing with a nylon-cleaning pad impregnated with a surface protectant material is also recommended for removing stubborn soils and stains. After scrubbing, the surface should be rinsed thoroughly with clean water to remove all residue.

In some circumstances it may be desirable to wipe the surface with a solvent. The surface is then permitted to air dry or is wiped dry with a chamois, squeegee or lint-free cloth.

Using power-cleaning tools may be necessary to remove unusually heavy soils from large areas including panels and column covers. When using such tools, the surface must be continually flushed with clean water or a mild detergent cleaning solution to provide lubrication and a medium for carrying away the dirt. After an area has been machine scrubbed, it must be rinsed with clean water and thoroughly scrubbed with a fairly stiff bristle brush. The surface may then be air dried or wiped dry.

Inspection & Cleaning Precautions

Care must be taken to see that metal seams, crevices, sills and other areas that can trap water, cleaner or dirt are carefully cleaned and dried. A final inspection, by a qualified representative is recommended, to ensure that no discoloration or stains remain on the surface.

Certain precautions must be taken when cleaning anodized aluminum surfaces. Aluminum finishes must first be identified to select the appropriate cleaning method.

- Aggressive alkaline or acid cleaners must never be used.
- Cleaning hot, sun-heated surfaces should be avoided since possible chemical reactions will be highly accelerated and cleaning non-uniformity could occur.
- Strong organic solvents, while not affecting anodized aluminum, may extract stain-producing chemicals from sealants and may affect the function of the sealants.
- Strong cleaners should not be used on window glass and other components where it is possible for the cleaner to come in contact with the aluminum.

Excessive abrasive rubbing should not be used since it could damage the finish.

PRODUCT DEVELOPMENT

A continuing research and development program ensures a high standard of quality in design, workmanship and service performance. This Installation and Maintenance Manual may differ slightly from current production models as a result of this continuing R&D program.



CJ Rush Entrance Systems Ltd.

65 Riviera Drive, Markham Ontario L3R5J6

T: 905 944 8005 Toll Free: 1-888-301 5407

Email: sales@cjrush.com

Website: www.cjrush.com